

Scaper's Flow

Hang-on external filter for aquaria





Scaper's Flow

An aquarium without technology is not possible, but with the Dennerle Scaper's Flow we banish the filter technology to the outside. For every situation, whether with a black or transparent back wall, the backpack filter comes with the right intake tubes and Lily Pipe.

The filter is equipped with all filter materials and comes pre-assembled for immediate use.

- Easy handling: completely removable, easy to clean
- Smooth and quiet operation
- With height-adjustable and swivelling Lily Pipe
- Suction pipe incl. filter sponge as suction protection
- Pump capacity 450 L/h, delivery head up to a maximum of 60 cm
- Plug & Play

Flexible fitting

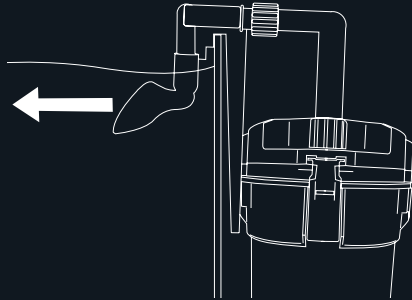

- Minimal surface movement helps to conserve CO₂



- For swift supply of oxygen
- For cleaning the water surface



Technical data

Power cord 1.40 m
Filter capacity 450 L/h
Filter volume 2 L
AC 230 V / 50 Hz
5.6 W
10 - 35 °C

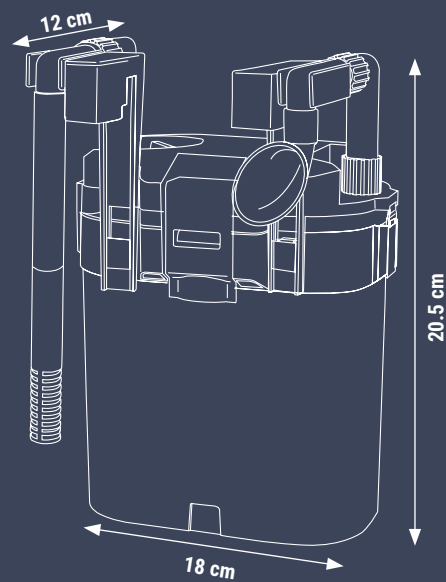

Filter materials

Accessories included



Data

Order No.	Product name	EAN	PU
4573	Scaper's Flow	4001615045734	1

Dennerle GmbH
Industriestr. 4
66981 Münchweiler
Germany

E-Mail: order@dennerle.com
Tel.: +49 6395 9107 400

 [@dennerle.official](https://www.instagram.com/dennerle.official)

 [/dennerle](https://www.facebook.com/dennerle)

 [/dennerle](https://www.youtube.com/dennerle)

